

TOP Transfer

Force transfer standard



Special features

- Force transducer with ultimate precision for international comparison measurements
- Tensile/compressive force transducer
- Nominal forces 100 N ... 500 kN
- Excellent rel. repeatability error
- High long-term stability

TOP-Z30A

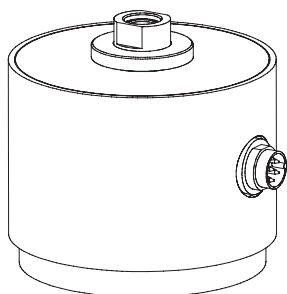

TOP-Z4A

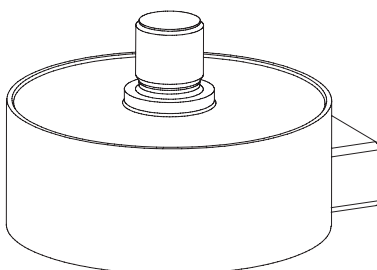

Nominal force Order number

100 N	1-TOP-Z30A/100 N
200 N	1-TOP-Z30A/200 N
500 N	1-TOP-Z30A/500 N
1 kN	1-TOP-Z30A/1000 N
2 kN	1-TOP-Z30A/2 kN
5 kN	1-TOP-Z30A/5 kN
10 kN	1-TOP-Z30A/10 kN

20 kN	1-TOP-Z4A/20 kN
50 kN	1-TOP-Z4A/50 kN
100 kN	1-TOP-Z4A/100 kN
200 kN	1-TOP-Z4A/200 kN
500 kN	1-TOP-Z4A/500 kN

Technical data Compressive force

Type	TOP-Z30A						TOP-Z4A							
Data per VDI 2638 and ISO 376														
Nominal force ¹⁾	F _{nom}	N	100	200	500	1000								
		kN					2	5	10	20	50	100	200	500
Nominal (rated) sensitivity	C _{nom}	mV/V	2						2					
Rel. sensitivity error (compression)	d _c	%	< ±0.1						< ±0.1					
Rel. sensitivity variation (tensile/compression)	d _{zd}	%	< ±0.1						< ±0.2					
Rel. zero signal error	d _{s,0}	mV/V	< ±0.1						< ±0.01					
Relative repeatability error (0.2F_{nom} to F_{nom}) for:														
Unchanged mounting position	b'	%	< ±0.002						< ±0.003					
Various mounting positions	b													
Compressive force		%	< ±0.005						< ±0.008					
Tensile force		%	< ±0.01						< ±0.016					
Rel. interpolation error (0.2F_{nom} to F_{nom})	f _c	%	< ±0.002						< ±0.002					
Relative zero error (zero signal return)	f _o	%	< ±0.004						< ±0.004					
Relative reversibility error (0.2F_{nom} to F_{nom})	v	%	< ±0.03						< ±0.03 ²⁾					
Effect of temperature on sensitivity/10 K related to nominal sensitivity	TK _c	%	< ±0.015			< ±0.01			< ±0.01					
Effect of temperature on zero signal/10 K related to nominal sensitivity	TK ₀	%	< ±0.015			< ±0.01			< ±0.015					
Relative creep over 20 min	d _{crF+E}	%	< ±0.01											
Effect of lateral forces (lateral force 10% F_{nom})³⁾	d _Q	%	< 0.1						< 0.03					
Effect of eccentricity per mm	d _E	%	< 0.005						< 0.01		< 0.005			
Input resistance	R _e	Ω	>345			>690			>345					
Output resistance	R _a	Ω	300-500			600-800			356 ± 0.3					
Insulation resistance	R _{is}	Ω	>5·10 ⁹											
Reference excitation voltage	U _{ref}	V	5											
Operating range of the excitation voltage	B _{U,G}	V	0,5 ... 12											
Nominal temperature range	B _{t,nom}	°C	+17...+27											
Operating temperature range	B _{t,G}	°C	0...+40											
Storage temperature range	B _{t,S}	°C	-10...+70											
Reference temperature	t _{ref}	°C	+22											
Max. operational force	(F _G)	%	120			150			150					
Limit force	(F _L)	%	150						150					
Breaking force	(F _B)	%	250						250					
Lateral limit force	(F _Q)	%	60						30					
Limit torque	(M _G)	N·m	3	5		80		120	350	950	2000	4000		
Nominal displacement	S _{nom}	mm	< 0.4			approx. 0.2			0.2	0.25	0.28	0.45		
Fundamental resonance frequency	f _G	kHz	0.3	0.5	0.9	1.1	1.1	1.25	4.1	4.5	3.4	3.6	2.5	
Rel. permissible oscillatory stress	F _{rb}	%	70						70					
Weight		kg	approx. 0.9			approx. 2.3			1.8	2.4	5.5	11.2	42	
Degree of protection per DIN 60529			IP 50						IP 67					
Cable length, six-wire circuitry	m		-						6					
Plug connection			Radial and axial housing plug, Binder series 723						-					
Transducer identification			TEDS, per IEEE 1451.4						-					

¹⁾ 100 to 1000 N: Including overload protection

²⁾ for tensile force TOP-Z4A/500 kN: 0,07%

³⁾ corresponds to the half pin height for the TOP-Z4A

The TOP Transfer force transducers are only available in conjunction with a DKD calibration to ISO 376 (not included in scope of supply).

TOP-Z30A

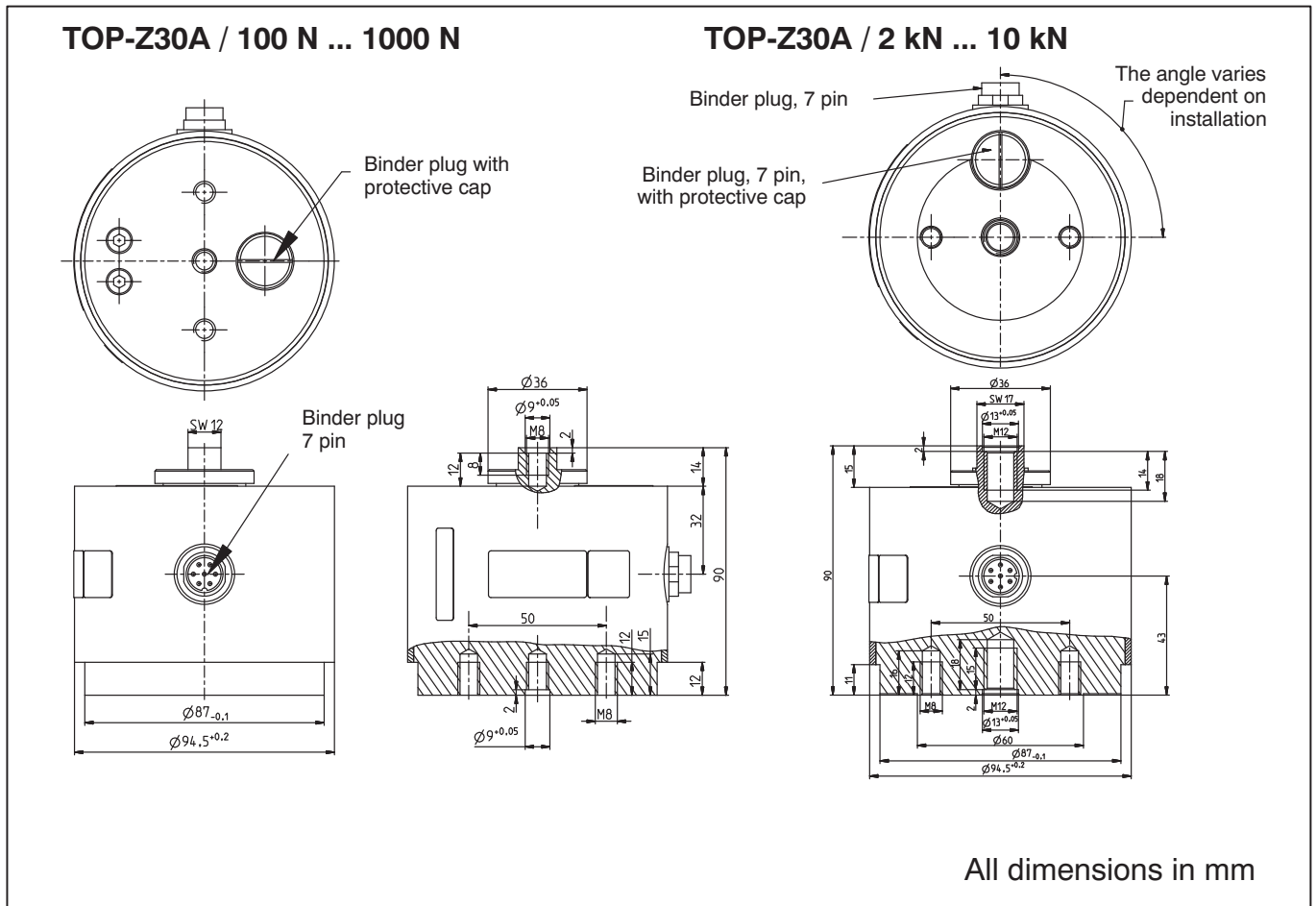

TOP-Z4A

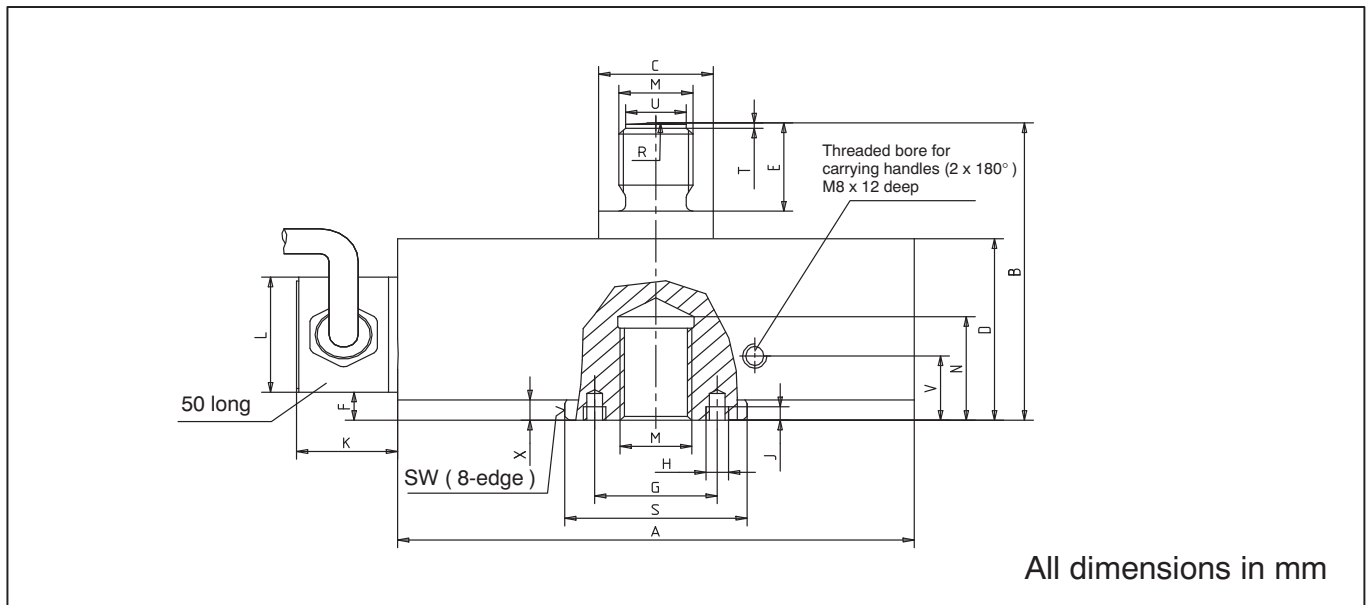

Type	∅ A	B	∅ C _{T7}	D	E	F	G	H	J	K	S	M	N	R	∅ S _{T7}	T	∅ U	V	X	SW
TOP-Z4A/20kN	115	77	25	47	23	7.3						M16	27	60	40	1.4	13		5.3	38
TOP-Z4A/50kN	120	83	26	55	23	10.2						M20x1.5	28	60	48	1.4	17		8.2	45
TOP-Z4A/100kN	146	107	40	69	33	12.2				22	30	M30x2	37	160	62	1.4	27		10.2	59
TOP-Z4A/200kN	180	137	50	89	43	13.1	68	M6	6			M39x2	45	160	76	1.8	36		11.1	73
TOP-Z4A/500kN	275	250	100	145	95	21	118	M8	8	32	43	M72x4	87	400	140	3	65	35	20	134

Pin assignment TOP-Z4A connection cable and TOP-Z30A plug and connection cable KAB139A-6

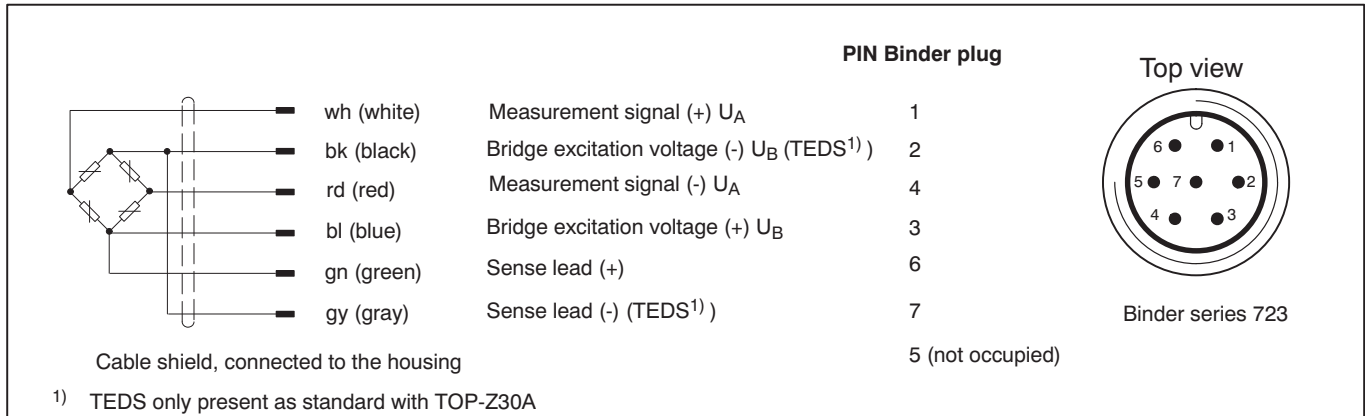

Cables/plugs

Order number	
1-KAB139A-6	Connection cable Kab139A-6, 6 m, with Binder female cable connector and free ends
D-MS/MONT	Connector MS3106PEMV mounted on cable
D-15D/MONT	15 pin D-plug, mounted on cable
D-TEDS/MONT_DB	TEDS ready mounted in 15 pin D-plug for Z4A

Accessories TOP-Z30A (not included in scope of supply)

Force application parts for tensile loading

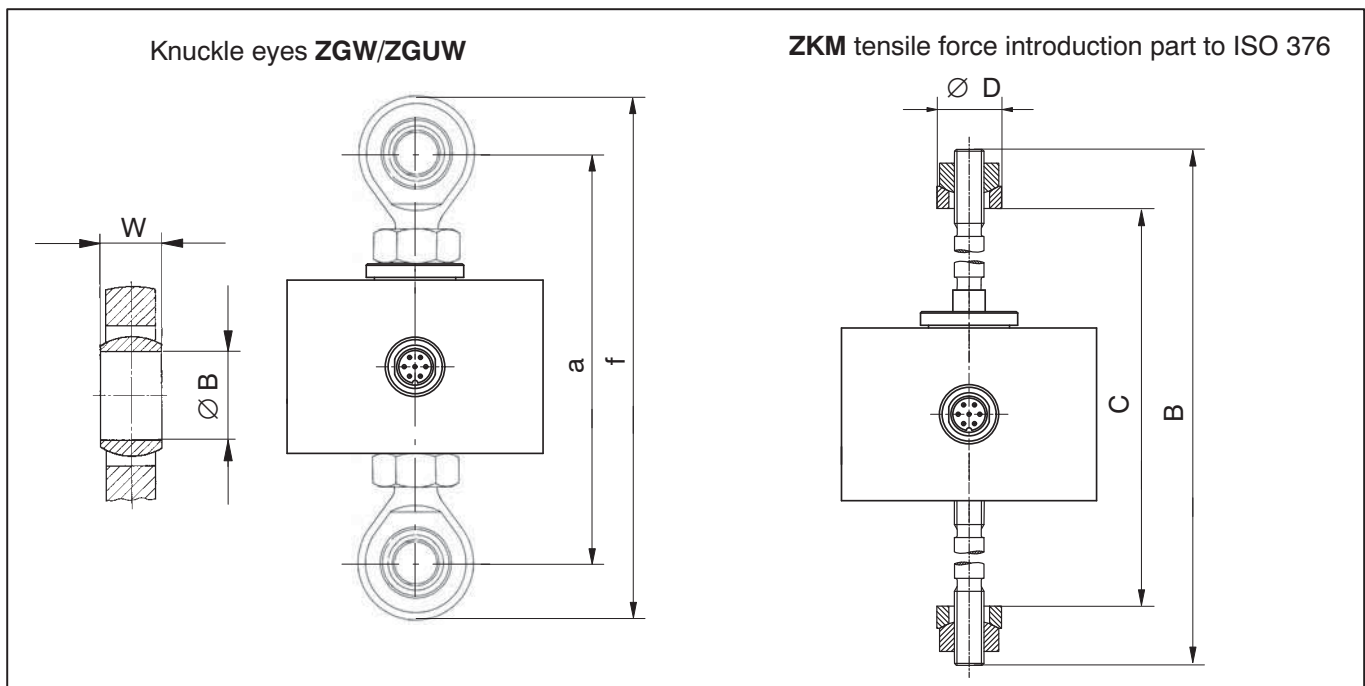

Type	ZKM Order number	B	C		Ø D
			min	max.	
TOP-Z30A/2kN - 10kN	1-Z30/10kN/ZKM	229	250	312	35 -0.120 -0.280

Type	Knuckle eye top/bottom Order number	a	f	W	Ø B
TOP-Z30A/100N - 1000N	1-U1R/200kg/ZGW	138	170	12	8 ^{H7}
TOP-Z30A/2kN - 10kN	1-U2A/1t/ZGUW	169	201	16	12 ^{H7}

Load button for compressive loading

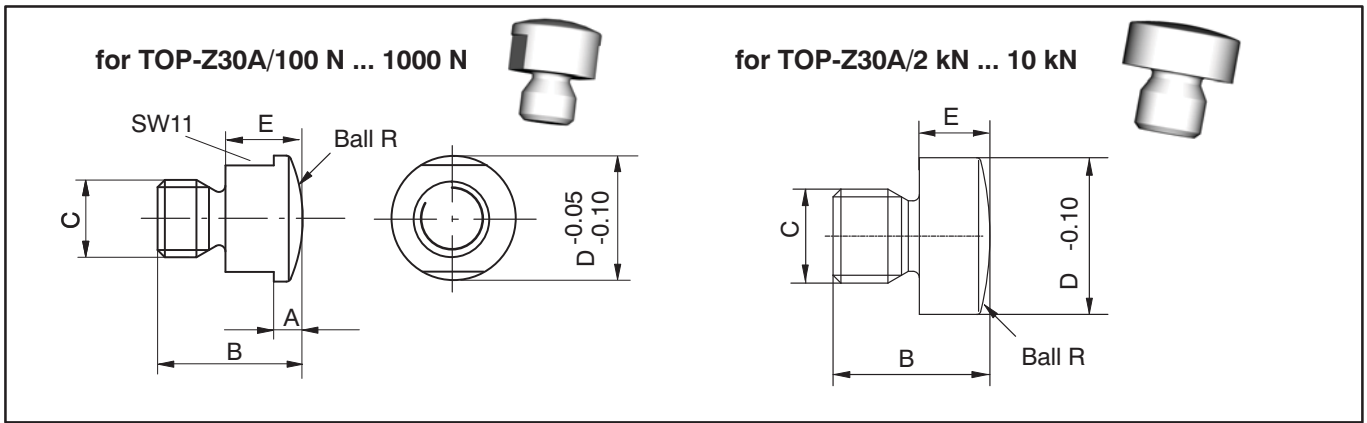

Type	Load button Order number	A	B	C	D	E	R
TOP-Z30A/100N - 1000N	1-U1R/200kg/ZL	3	15	M8	13	8	16
TOP-Z30A/2kN - 10kN	3-9202.0140	-	20	M12	20	9	40

Thrust piece for compressive loading

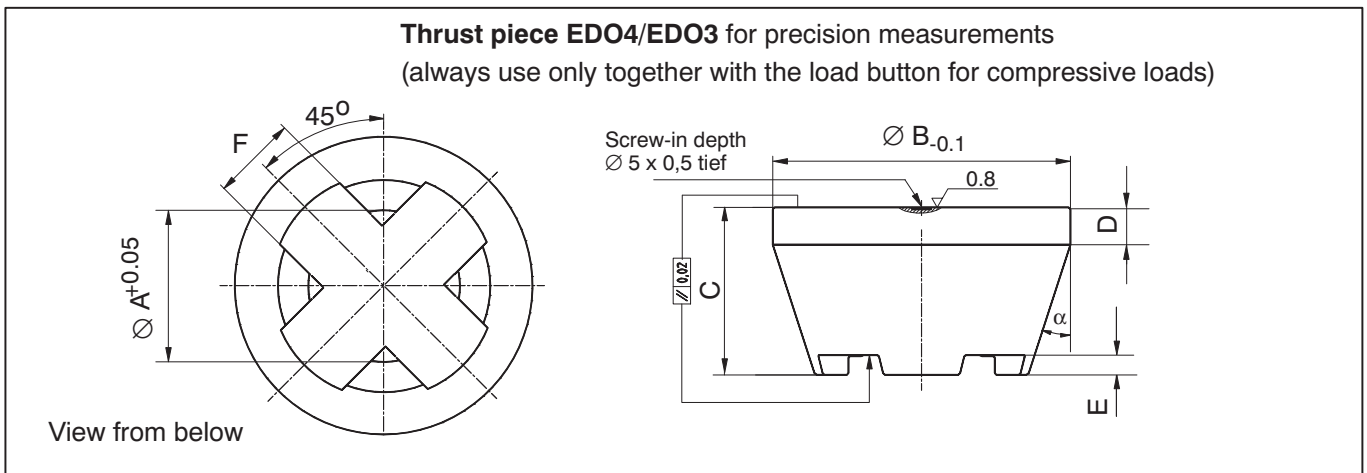

Type	Thrust piece Order number	Weight (kg)	∅ A	∅ B	C	D	E	F	α
TOP-Z30A/100N - 1000N	1-EDO3/1kN	approx. 0.2	13.2	37	22	6	3	8	18°
TOP-Z30A/2kN - 10kN	1-EDO4/50kN	0.34	20.2	48	29	8	5	12	18°

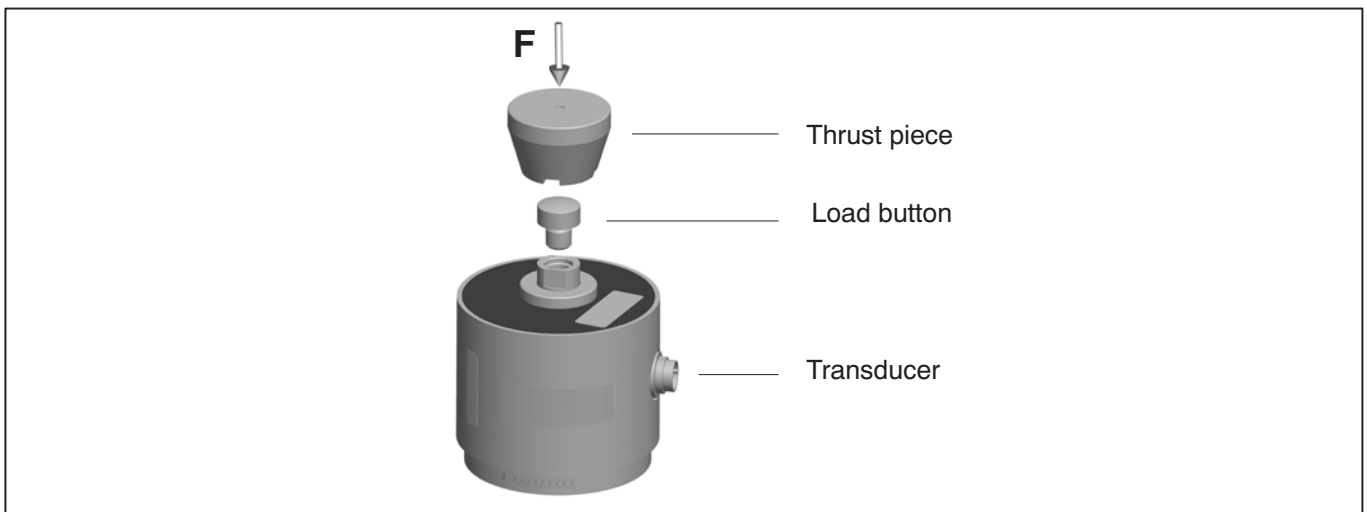



Transport case for 4 TOP-Z30A force transducers and accessories

Order No.: 1-Z30/BOX
 Dimensions: 440 x 320 x 147mm

Accessories TOP-Z4A (not included in scope of supply)

Knuckle eyes ZGOW/ZGUW for tensile loading

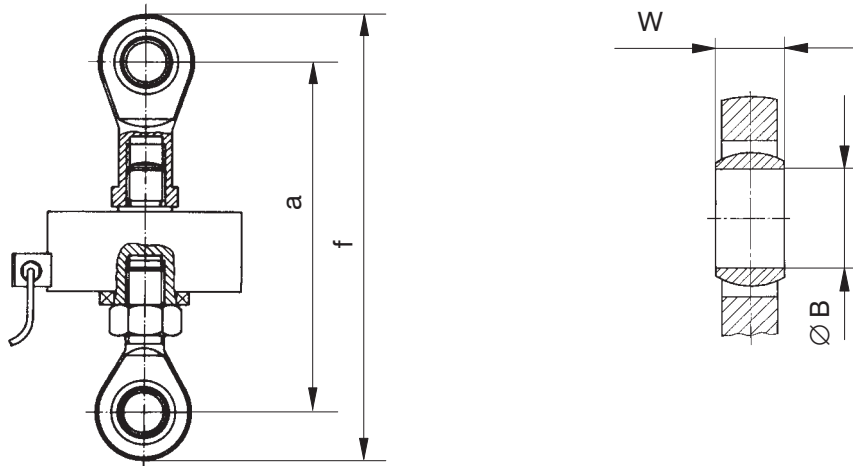

Type	Knuckle eye top Knuckle eye bottom Order No.	Weight (kg)	a		f		W	Ø B
			min	max.	min	max.		
TOP-Z4A/20 kN	1-Z4/20kN/ZGOW 1-Z4/20kN/ZGUW	0.2	approx. 158	approx. 170	approx. 198	approx. 210	21	16 ^{H7}
TOP-Z4A/50 kN	1-U2A/2t/ZGOW 1-U2A/2t/ZGUW	0.8 0.4	approx. 190	approx. 199	approx. 245	approx. 254	25	20 ^{H7}
TOP-Z4A/100 kN	1-Z4/100kN/ZGOW 1-Z4/100kN/ZGUW	1.1	approx. 261	approx. 269	approx. 331	approx. 339	37	30 ^{H7}
TOP-Z4A/200 kN	1-U2A/10t/ZGOW 1-U2A/10t/ZGUW	3.2 1.1	approx. 352	approx. 357	approx. 475	approx. 480	35	50 ^{+0.001} -0.014
TOP-Z4A/500 kN	1-Z4/500kN/ZGOW 1-Z4/500kN/ZGUW	17.3 12.0	approx. 570	approx. 590	approx. 764	approx. 784	44	60 ^{+0.003} -0.018

Force application parts to ISO 376

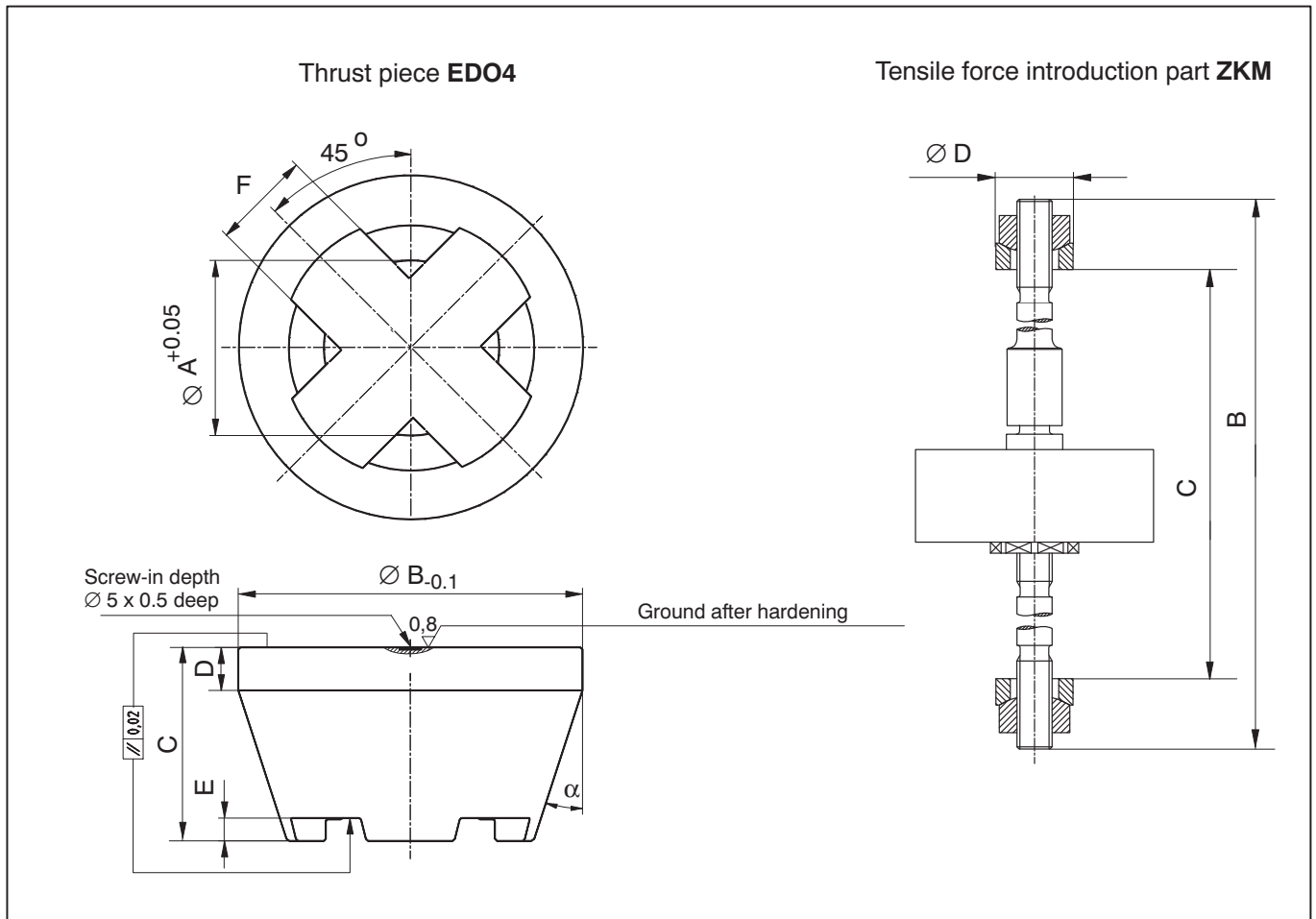

Type	Thrust piece Order No.:	Weight (kg)	$\varnothing A$	$\varnothing B$	C	D	E	F	α
TOP-Z4A/20kN	1-EDO4/20kN	0.34	16.2	48	29	8	5	12	18°
TOP-Z4A/50kN	1-EDO4/50kN		20.2		29		5		
TOP-Z4A/100kN	1-EDO4/100kN	1.58	30.2	80	45	10	5	23	
TOP-Z4A/200kN	1-EDO4/200kN		39.2						
TOP-Z4A/500kN	1-EDO4/500kN	4.35	72.4	112	68	15	12	30	15°

Type	ZKM Order No.:	Weight (kg)	B	C		$\varnothing D$
				min	max.	
TOP-Z4A/20kN	1-Z4/20kN/ZKM	0.82	325	228	276	35 -0.120 -0.280
TOP-Z4A/50kN	1-Z4/50kN/ZKM	1.45	350	248	299	45 -0.130 -0.290
TOP-Z4A/100kN	1-Z4/100kN/ZKM	2.32	395	277	334	50 -0.130 -0.290
TOP-Z4A/200kN	1-Z4/200kN/ZKM	4.19	447	317	382	64 -0.140 -0.330
TOP-Z4A/500kN	1-Z4/500kN/ZKM	20.1	623	432	522	90 -0.170 -0.390

Regional Distributor



803, Riqqa Palace Building
Al-Maktum Ave.
P.O.Box 181802 Dubai, UAE
Tel: +9714 - 2270081
Fax: +9714 - 2239962
E-mail: rscso@eim.ae
www.rcs-co.com

Hottinger Baldwin Messtechnik GmbH

Im Tiefen See 45, D-64293 Darmstadt, Germany
Tel.: +49 6151 8030; Fax: +49 6151 803 9100
E-mail: support@hbm.com www.hbm.com



measurement with confidence